

Signal Consulting, LLC

16 Wilelinor Drive, Edgewater, MD 21037-1003, USA

Phone: 410-224-8429, Fax: 410-510-1821, E-mail: info@signalllc.com

Model **Si20HPB4-50V-20A-AP1**

50V-20A High Power H-Bridge with Aluminum Plate Heat Sink for Bidirectional DC Motor Control

Si20HPB4-50V-20A-AP1 Features:

- Four 90A Hex MOSFETs
- 100% Solid-State Components (no relays)
- Pulse-Width Modulation (PWM from 0-20 kHz) for Bi-directional Speed Control.
- The PWM Control Lines are Optically Isolated from the Motor-Power Circuits.
- 0 to 5 V (TTL) for Control-Voltage Inputs, with 0 to 100% duty-cycle variation for PWM.
- **Voltage Requirement:** Single 9V to 50V DC Power Supply
- **Max. Continuous Load (or Motor) Current:** +/- 20 A at 60 Hz PWM, and +/- 2 A at 20 kHz PWM and the board Mounted on a large metal frame.
- **Max. Load-Surge (or Motor) Current for 2 sec:** +/- 50 A.
- **Typical Operating Temperature:** 45⁰C at 16A with the board mounted on a 4" by 3.3"x0.062" metal plate and exposed to air at 25⁰C. Please click on this link and read the [Board Mounting Instructions and Heat Sink Selection Guide](#).
- **Overall Dimensions:** L=4.0", W=3.3", H=1.5"; (L=102mm, W=84mm, H=38mm)

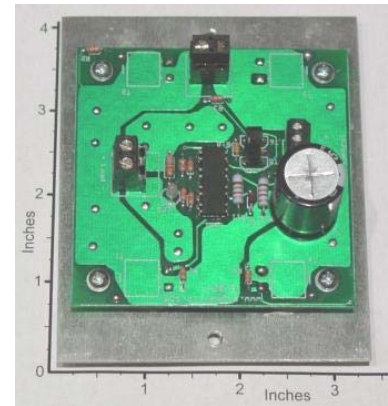

The **Si20HPB4-50V-20A-AP1** is an efficient high-power H-bridge **with an integrated (4"x3.3"x0.062") Aluminum Plate Heat Sink** that works over a wide range of source voltages (9V to 50V) at high continuous load currents (+/-20A max). Higher current values can be attained with more efficient heat sinks. The motor action (as shown on the truth table below) is controlled by the voltages applied to pin **F** and pin **R** (relative to pin **C**) on the **Control** connector (shown on the application drawing below). **These pins are optically isolated from the rest of the power circuit, requiring a minimum input current of 1.5 mA at 3.5V and max input current of 7mA at approx. 9V.** An external resistor, (connected in series with each control input F and R) can be used when higher control voltages are required (1kΩ for 12V, 2.2kΩ for 24V).

Control Input Truth Table (for Control connector)

V _{FC}	V _{RC}	Motor / Load Action
LOW = 0 Volts	LOW = 0 Volts	Motor Stop / Load Current OFF
HIGH = 5 Volts	LOW = 0 Volts	Motor Forward / + Load Current
LOW = 0 Volts	HIGH = 5 Volts	Motor Reverse / - Load Current
HIGH = 5 Volts	HIGH = 5 Volts	NOT Recommended*

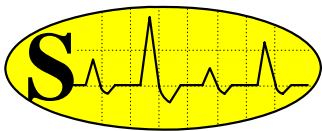

Signal Consulting, LLC

16 Wilelinor Drive, Edgewater, MD 21037-1003, USA

Phone: 410-224-8429, Fax: 410-510-1821, E-mail: info@signallc.com

*** When V_{FC} and V_{RC} are HIGH at the same time, the motor will spin forward or reverse depending which control signal arrives first; but no damage will occur to the load, board or the power source.**

- The V_{FC} and V_{RC} control lines can be Pulse-Width Modulated (PWM in a range of 0-20k HZ) to vary the average current supplied to a load or to a DC Motor.
- A bicolor LED is used to monitor the load voltage (Forward = Red, Reverse = Green).

Voltage Requirement: The Si20HPB4 will work with any DC motor in the 9 V to 50 V range. In addition, the power filters are included on this board. Consequently, only unregulated DC input power is required in most applications. Furthermore, the control circuit is optically isolated from the power circuit; rejecting unwanted power glitches.

Frequency Response of the Si20HPB4-50V-20A-AP1

The **Si20HPB4** control inputs (V_{fc} , V_{rc}) can be Pulse Width Modulated (PWM with duty-cycle of 0% to 100%) over a wide range of carrier frequencies, as shown on the graph. This plot was obtained with the board mounted on a 4.0" x 3.3" x 0.062" Aluminum Plate, placed on a nonmetallic bench top and exposed to 25 degree C air. Improved performance (20A) can be achieved with the board mounted on a metal frame (- - With Extra Heat Sink). Please click on this link and read the [Board Mounting Instructions and Heat Sink Selection Guide](#).

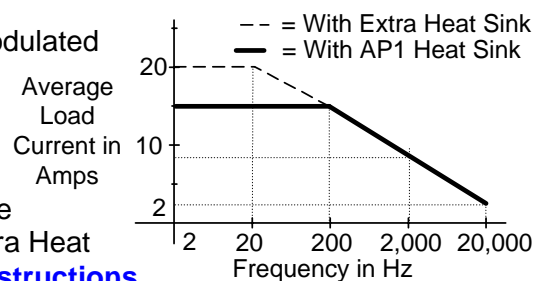

A Typical Motor Control Application of the Si20HPB4-50V-20A-AP1

In this bidirectional speed control application, the motor speed and direction is controlled by 2 external signals connected to pin **F (Forward)** and to pin **R (Reverse)** on the **Control** connector. These two (0 to +5V, relative pin **C**) inputs can be Pulse-Width Modulated over a wide Frequency range. These three pins are optically isolated from the power supply and the load.

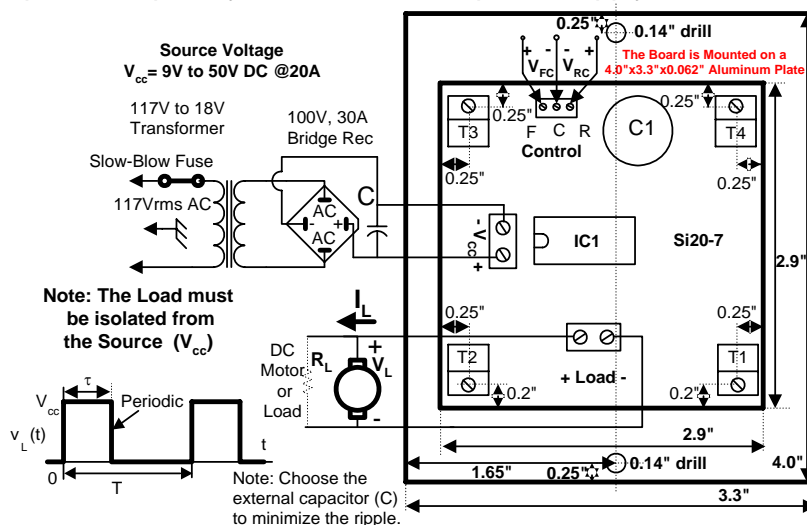

Warning: The connecting wires to the Load and the Power Supply must be heavy gauge copper wire (#12 AWG or heavier) to handle the rated current level. In addition, these heavy gauge wires act as a heat sink, protecting the board from overheating.

Typical Applications: Power Driver for Variable-Speed Bidirectional DC Motors, Peltier Effect TE Cells, Heat Pumps, PPDT Solid State Relays.